

Corte A-A
Eixo de entrada

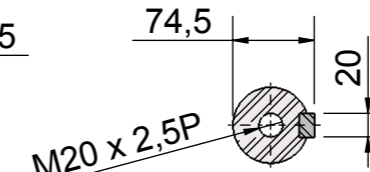

Corte B-B
Eixo de saída

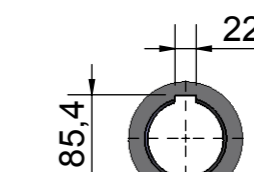

Detalhe C
Eixo de saída vazado

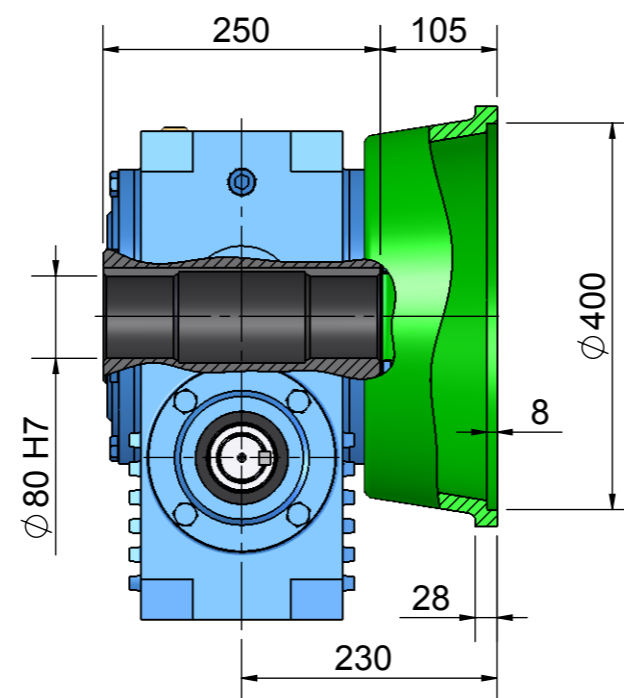
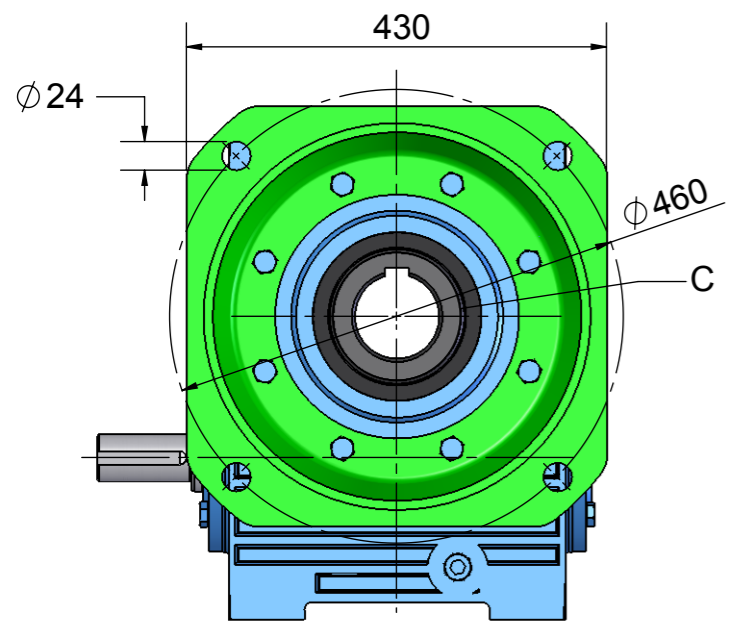

Acessórios para fixação

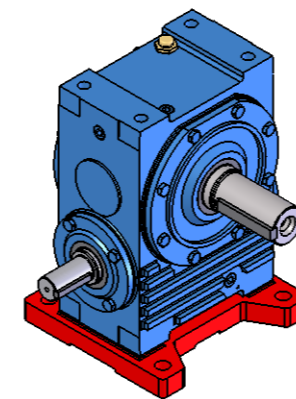

Pé

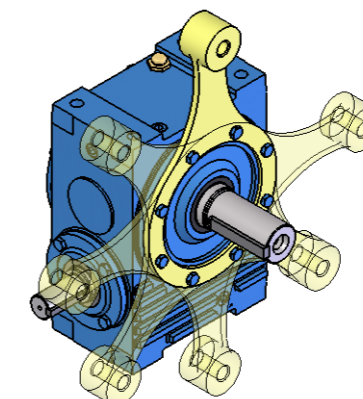

Braço de torção

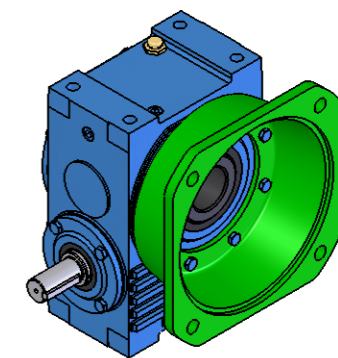

Base

MODELO

Regime de trabalho uniforme
10h/dia, 10 arranques/h

Redução Nominal Tabelada - Padrão de linha

10 15 20 25 30 40 50 60 80

CR-1700

Potência máx. admitida na entrada	CV	40,50	29,29	24,29	22,09	17,09	15,79	12,99	10,79	7,69
Momento de torção na saída	Kgf.m	152,90	154,63	169,14	183,07	159,47	196,06	180,75	174,87	151,06
Rendimento %	h	0,90	0,86	0,83	0,81	0,76	0,74	0,68	0,66	0,60
Redução efetiva	i	10,25	15,00	20,50	25,00	30,00	41,00	50,00	60,00	80,00
Redução efetiva no eixo de saída	n2	170,73	116,67	85,37	70,00	58,33	42,68	35,00	29,17	21,88