

Corte A-A
Eixo de entrada

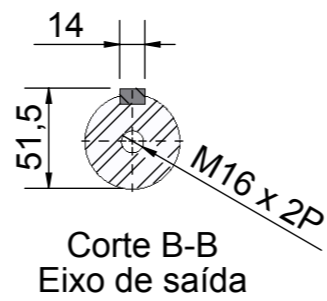

Corte B-B
Eixo de saída

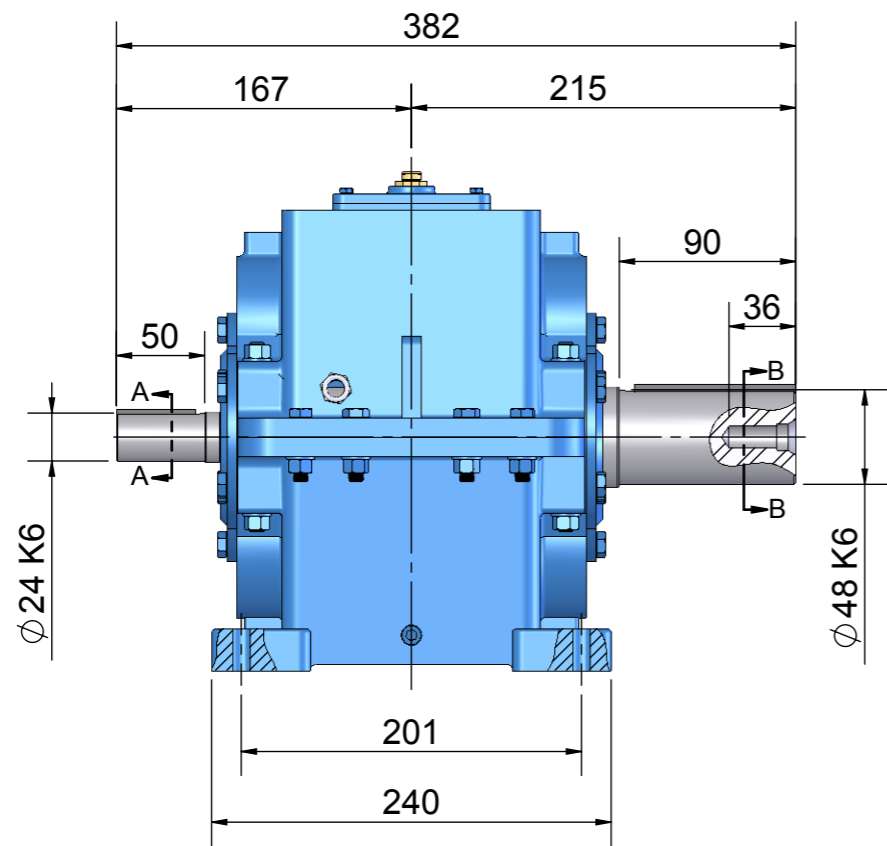
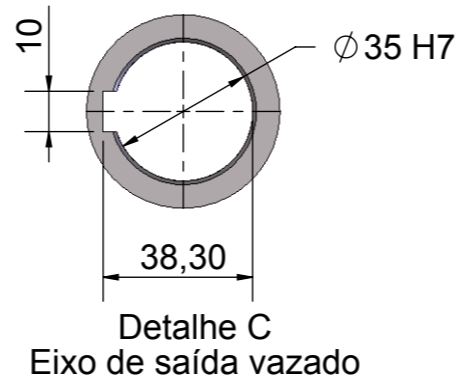
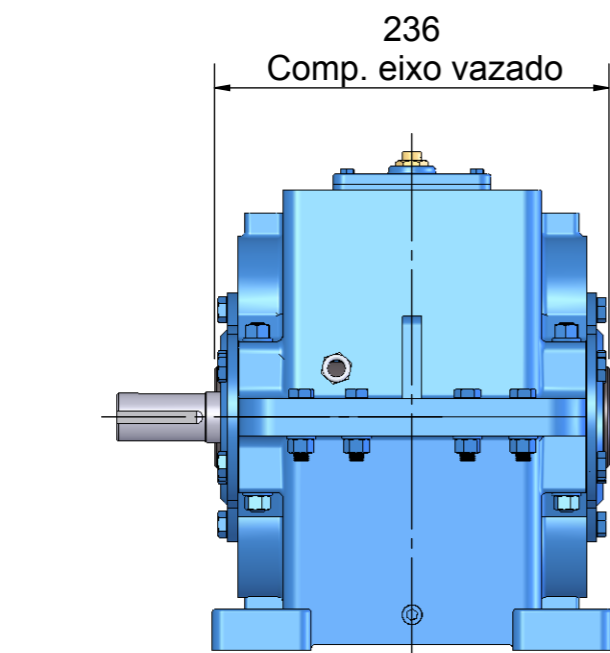
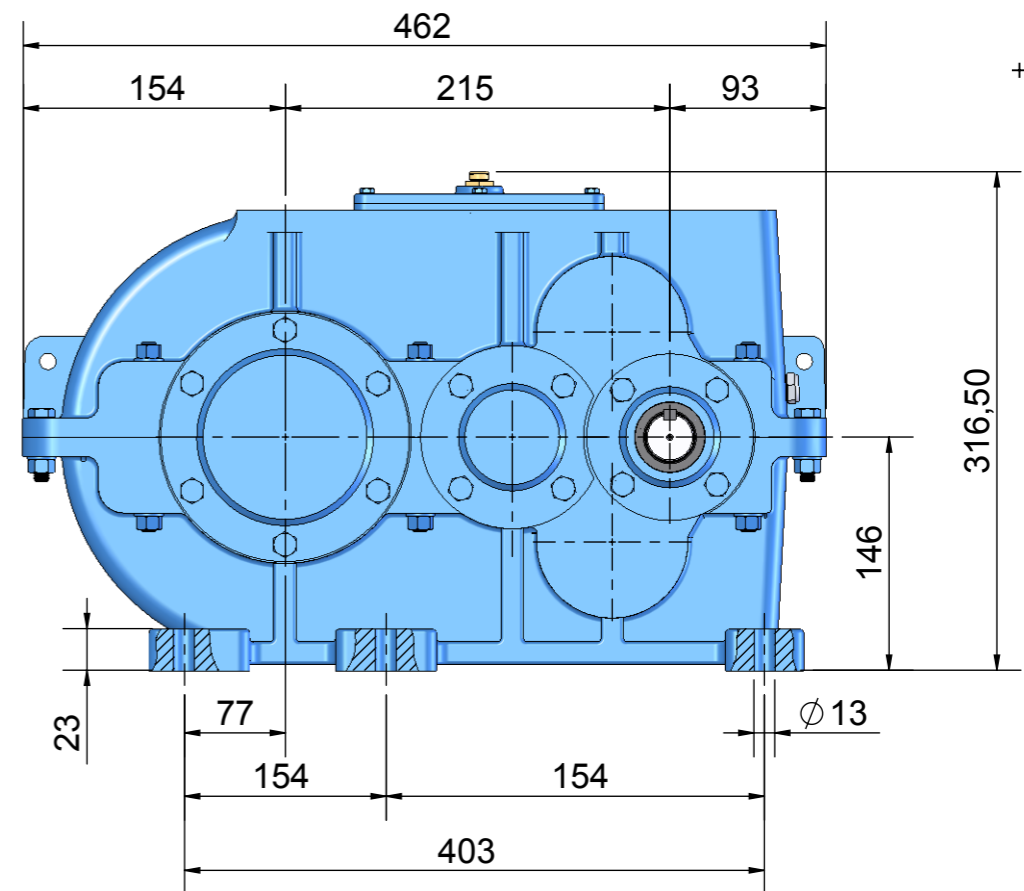

Detalhe C
Eixo de saída vazado

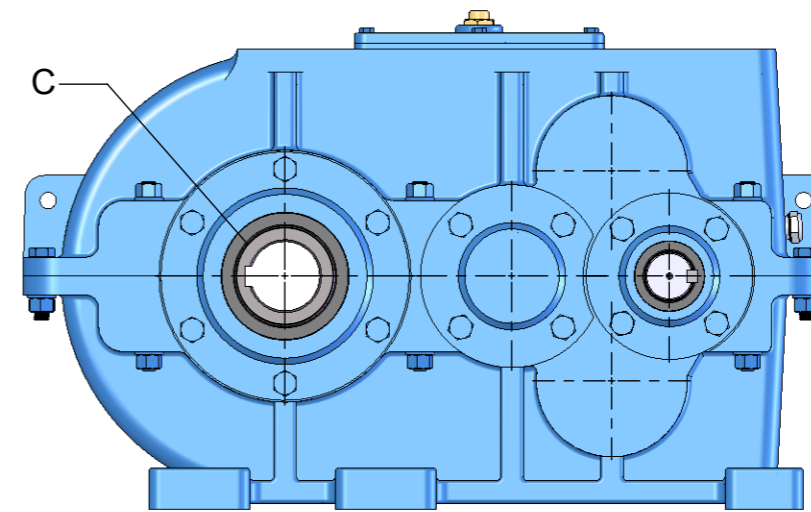

MODELO Regime de trabalho uniforme 10h/dia, 10 arranques/h Redução Nominal Tabelada - Padrão de linha

MODELO		6,3	7,1	8	9	10	11,2	12,5	14	16	18	20	22,4	25	28	31,5	35,5	40	45	
CH-215D	Potência máx. admitida na entrada	CV	34,81	30,01	26,00	23,44	21,56	19,21	17,34	15,34	13,33	12,05	10,63	9,48	8,62	7,67	6,75	6,15	4,52	4,87
	Momento de torção na saída	Kgf.m	82,76	82,78	82,72	82,78	82,78	82,77	82,78	82,74	82,72	82,79	82,77	82,79	82,74	82,77	82,73	82,74	70,42	82,77
	Momento de torção na saída	N.m	811,87	812,07	811,48	812,07	812,07	811,97	812,07	811,67	811,48	812,16	811,97	812,16	811,67	811,97	811,58	811,67	690,82	811,97
	Redução efetiva	i	6,18	7,17	8,27	9,18	9,98	11,20	12,41	14,02	16,13	17,86	20,24	22,70	24,95	28,05	31,86	34,97	40,50	44,18
	Rotação efetiva no eixo de saída	n2	283,17	244,07	211,61	190,63	175,35	156,25	141,02	124,82	108,49	97,98	86,46	77,09	70,14	62,39	54,93	50,04	43,21	39,61

